

### Kiểu E3 Model

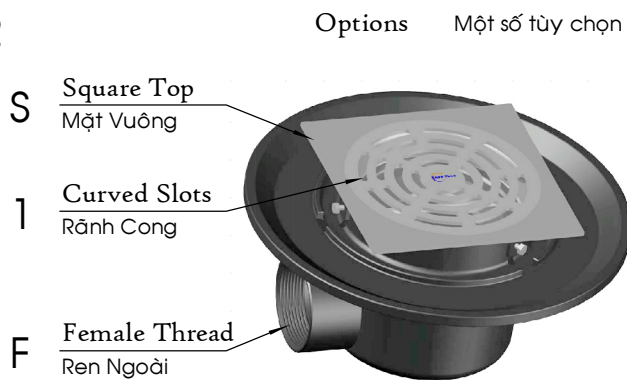
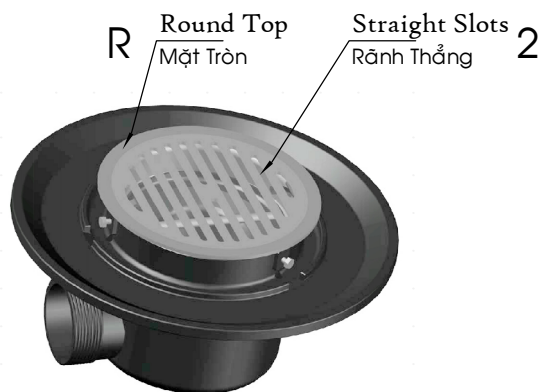
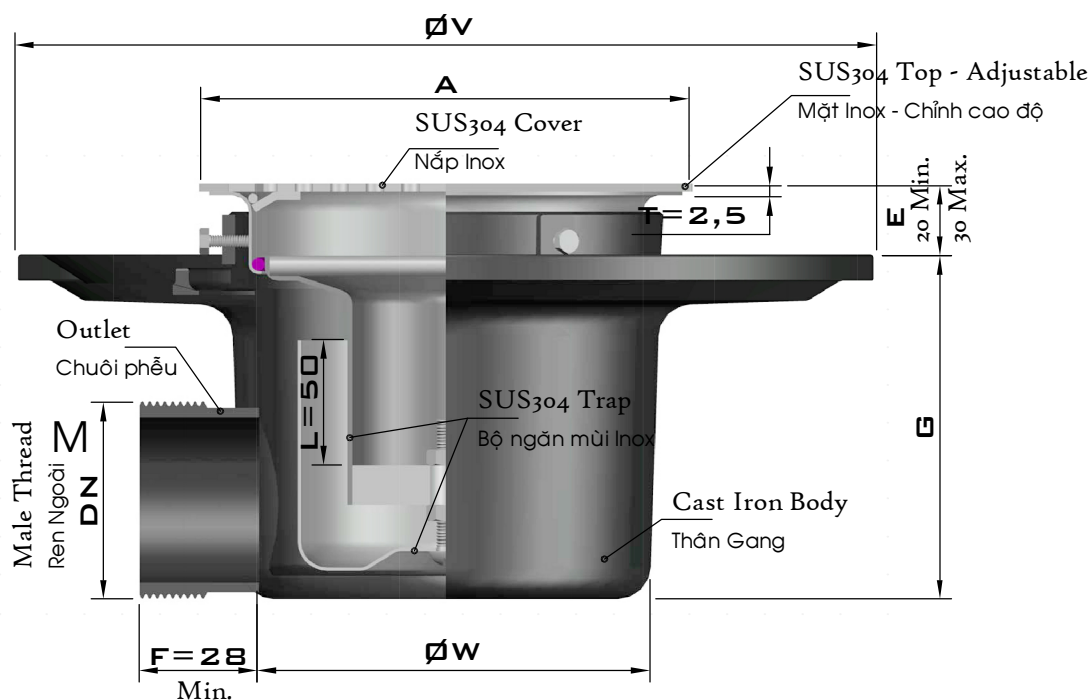

Pipe Size	ØD <sub>e</sub>	A	ØW	ØV	G	Free Area	Code	Outlet Threading: Female/Male
Kích thước Ống	(in) (mm)	(mm)	(mm)	(mm)	(mm)	Diện tích Rãnh thoát (mm <sup>2</sup> )	Mã số	Chuôi Ren Trong/Ngoài F/M
DN40	1 1/2 49	120	110	220	91	2,700	E3049 ? 120 S 1 1 2C	F/M
DN50	2 60	120	110	220	91	2,700	E3060 M 120 S 1 1 2C	Round/Square Top Mặt Tròn/Vuông
DN50	2 60	150	130	260	105	4,300	E3060 M 150 ? 1 1 2C	R/S
DN65	2 1/2 75	150	130	260	105	4,300	E3075 M 150 S 1 1 2C	
DN80	3 90	150	130	260	105	4,300	E3090 M 150 S 1 1 2C	Curved/Straight Slots Rãnh Cong/Thẳng
DN80	3 90	240	210	330	130	9,000	E3090 M 240 S 1 ? 2C	1/2
DN100	4 110	240	210	330	130	9,000	E3110 M 240 S 1 1 2C	
DN100	4 114	240	210	330	130	9,000	E3114 M 240 S 1 1 2C	